



**JÄGER**

Umwelt-Technik



DATA SHEET

# JETFLEX<sup>®</sup> TD 65-2 G TUBE DIFFUSER

# JETFLEX® TD 65-2 G TUBE DIFFUSER

## Dimensions

Material	Tube diameter	ID-Sleeve	Wall thickness
EPDM	63 mm	~ 65 mm	1,9 ± 0,15 mm
Silikon	63 mm	~ 65 mm	1,5 ± 0,15 mm
PUR	63 mm	~ 65 mm	0,6 ± 0,1 mm



## Installation drawing

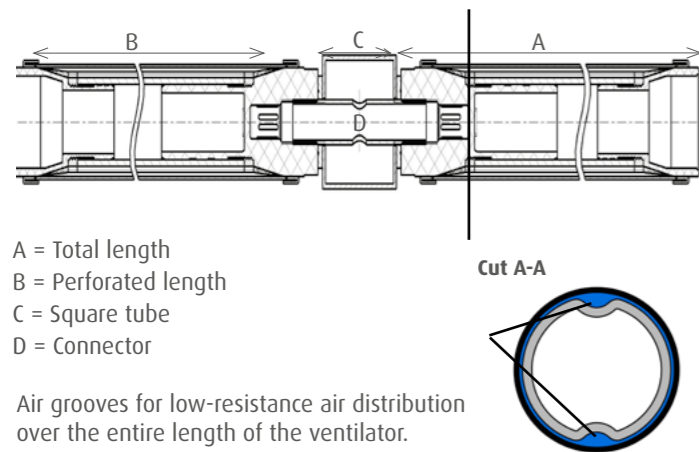

A = Total length  
B = Perforated length  
C = Square tube  
D = Connector

Air grooves for low-resistance air distribution over the entire length of the ventilator.

## SSOTE and headloss for EPDM 1000 mm

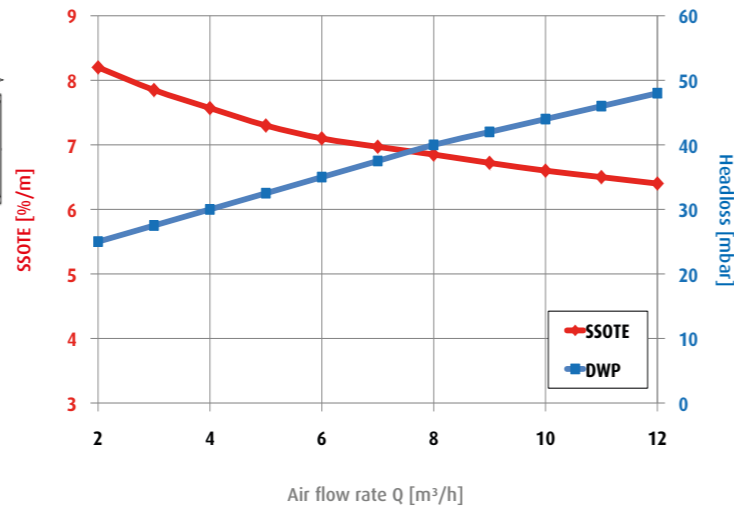

Perforation length [B]	Total length [A]	Perforated area		Air flow rate at standard operating conditions	Max overload/maintenance air flow rate	Operating mode
		EPDM+PU	SI			
1000 mm	1062,5 mm	0,18 m²	0,16 m²	2 - 12 Nm³/h	20 Nm³/h	continuous / intermittent
750 mm	812,5 mm	0,135 m²	0,12 m²	1,5 - 9 Nm³/h	15 Nm³/h	continuous / intermittent
500 mm	562,5 mm	0,09 m²	0,08 m²	1 - 6 Nm³/h	10 Nm³/h	continuous / intermittent

## Dimensions for connection to square pipes

Connector [D]	Length for square tube 80 x 80 mm [C]	Length for square tube 100 x 100 mm [C]	Drill hole for connector
Pipe thread ISO 228 - G 1A	145 mm	165 mm	35 +1/-0 mm
Pipe thread ISO 228 - G 3/4A	145 mm	165 mm	28 +1/-0 mm

For further details, please refer to our installation and operating instructions.

# JETFLEX® TD 65-2 G TUBE DIFFUSER

## Membrane materials

Material	Techn. standard	EPDMperformance Plus	PUR	Techn. standard	Silicone
Colour		black	green		translucent
Plasticiser (%)		35	0		0
Density (g/cm³)	DIN EN ISO 1183-1	1,11	1,15	DIN EN ISO 1183-1	1,16
Tensile strength (N/mm²)	DIN 53504	>8,5	>35	DIN 53504	>9
Elongation at break (%)	DIN 53504	>550	>500	DIN 53504	>900
Tear strength (N/mm)	DIN EN ISO 34-1	>10	>55	ASTM D 624 B	>38
Hardness (Shore A)	DIN ISO 7619-1	43 ± 5	87 ± 5	DIN 53505	60 ± 5
Operating temperature air (°C)		5 - 80	5 - 80		5 - 100
Operating temperature water (°C)		5 - 40	5 - 40		5 - 40

## Other materials

Supporting body	Stainless steel clamp
PP / PP 20% GF	1.4301

## Accessories



Adapter

Blind plug

Floor bracket and end plug

Seal

Half shell with external thread

For further information, please refer to our Accessories catalogue.

JETFLEX® TD 65-2 G TUBE DIFFUSER

# CONTACT

Tel +49 511 – 64644 0

Fax +49 511 – 64644 499

[www.jaeger-envirotech.com](http://www.jaeger-envirotech.com)

[info@jaeger-envirotech.com](mailto:info@jaeger-envirotech.com)



Jäger Umwelt-Technik GmbH  
Lohweg 1  
30559 Hannover

**Disclaimer**

We exclude any liability for the information and product presentations provided. For contents of a technical nature, these are based on the status of their publication. Existing copyrights and rights to names remain unaffected.

Grafic, Photos: ©Adobe Stock, Jäger data base